



PRI Evaluation Report

PRI ER 1378E01

Issue Date: 07/03/2019

Last Revision: 10/18/2022

This Report is Reviewed Annually

Visit: pri-group.com for current status.

Report Holder:

Owens Corning Roofing and Asphalt LLC

1 Owens Corning Parkway
Toledo, OH 43659
(419) 248-7060
owenscorning.com/roofing

SCOPE

Subject: Asphalt Shingles

CSI MasterFormat®:

DIVISION: 07 00 00 – THERMAL AND MOISTURE PROTECTION
Sub-level 2: 07 30 00 – Steep Slope Roofing
Sub-level 3: 07 31 00 – Shingles and Shakes
Sub-level 4: 07 31 13 – Asphalt Shingles

Code References:

- 2021, 2018, 2015, 2012, and 2009 International Building Code® (IBC)
- 2021, 2018, 2015, 2012, and 2009 International Residential Code® (IRC)

Properties Evaluated:

- External Fire Exposure (ASTM E108, ANSI/UL790)
- Wind Resistance (ASTM D3161; ASTM D7158)
- Physical Properties (ASTM D3462, ICC-ES AC438)
- Impact Resistance (UL 2218)

Evidence Submitted:

- Recognized test report(s) indicating compliance with ASTM E108 and/or ANSI/UL790
- Recognized test report(s) indicating compliance with ASTM D3161
- Recognized test report(s) indicating compliance with ASTM D7158
- Recognized test report(s) indicating compliance with ASTM D3462
- Recognized test report(s) indicating compliance with UL 2218
- Recognized test report(s) indicating compliance with ICC-ES AC438
- Quality Documentation
- Manufacturer’s Drawings and Installation Instructions

Manufacturing Locations:

<u>Factory ID</u>	<u>Location</u>
Atlanta, GA	4795 Frederick Dr. Atlanta, GA 30336
Brookville, IN	128 W 8th St. Brookville, IN 47012
Compton, CA	1501 N Tamarind St., PO Box 5665 Compton, CA 90224
Denver, CO	5201 Fox St. Denver, CO 80216
Houston, TX	8360 Market St. Rd. Houston, TX 77029
Irving, TX	201 N Nursery Rd. Irving, TX 75061
Jacksonville, FL	1035 Talleyrand Ave. Jacksonville, FL 32206
Kearny, NJ	1249 Newark Tpke. Kearny, NJ 07032
Medina, OH	890 W Smith Rd. Medina, OH 44256
Memphis, TN	704 Corrine Ave., N Station Memphis, TN 38107
Minneapolis, MN	1901 49th Ave. N Minneapolis, MN 55430
Portland, OR	NW Yeon Ave. Portland, OR 97208
Savannah, GA	1 Foundation Dr. Savannah, GA 31408
Summit, IL	5824 S Archer Rd. Summit, IL 60501



PRODUCT DESCRIPTIONS and APPLICATIONS

Products:

- Supreme®
- Oakridge®
- TruDefinition® Oakridge®
- Duration® Premium
- Duration® Premium COOL
- TruDefinition® Duration®
- TruDefinition® Duration® COOL
- TruDefinition® Duration® STORM®
- TruDefinition® Duration® MAX™
- TruDefinition® Duration® FLEX™
- TruDefinition® WeatherGuard® HP
- Berkshire®
- Woodcrest®
- Woodmoor®
- Starter Strip Plus
- Tri-Built Shingle Starter
- SRS TopShield Starter Shingle
- WoodStart® Starter Shingle
- ProEdge®
- ImpactRidge™ Hip & Ridge Shingles
- RIZERidge® Hip & Ridge Shingles with Sealant
- DuraRidge™ Hip & Ridge Shingles
- Berkshire® Hip & Ridge Shingles
- WeatherGuard® HP Hip & Ridge

Product Descriptions:

OWENS CORNING® asphalt shingles are roof covering materials that conform with the following properties when installed as instructed in this report. The products come in standard and metric sizes and consist of three-tab shingles, laminated shingles, and accessory shingles.

Three-tab (single-layer): Three-tab, fiberglass reinforced shingles. The shingles are manufactured with a single fiberglass mat, coated on both sides with asphalt, and surfaced on the weather-exposed side with mineral granules. The shingles are self-sealing and have a continuous bead of thermal-tab sealing adhesive above the shingle butt on the weather side.

Product:	Factory IDs:	Dimensions:
Supreme®	Denver, CO; Irving, TX; Medina, OH; Portland, OR	12" x 36"
Supreme®	Compton, CA; Portland, OR	13-1/4" x 39-3/8"

Laminated (multi-layer): Laminated shingles. The shingles are manufactured with 2 layers of fiberglass mat coated with asphalt on both sides, and surfaced on the weather-exposed side with mineral granules.

Product:	Factory IDs:	Dimensions:
Oakridge®	Atlanta, GA; Brookville, IN; Compton, CA; Denver, CO; Irving, TX; Jacksonville, FL; Kearny, NJ; Medina, OH; Memphis, TN; Minneapolis, MN; Portland, OR; Savannah, GA; Summit, IL	39-3/8" x 13-1/4"
TruDefinition® Oakridge®	Atlanta, GA; Irving, TX; Jacksonville, FL; Memphis, TN	39-3/8" x 13-1/4"
Duration® Premium	Compton, CA; Portland, OR	39-3/8" x 13-1/4"
Duration® Premium COOL	Compton, CA	39-3/8" x 13-1/4"
TruDefinition® Duration®	Brookville, IN; Compton CA; Denver, CO; Irving, TX; Jacksonville, FL; Kearny, NJ; Medina, OH; Memphis, TN; Minneapolis, MN; Portland, OR; Savannah, GA; Summit, IL	39-3/8" x 13-1/4"
TruDefinition® Duration® COOL	Compton CA	39-3/8" x 13-1/4"
TruDefinition® Duration® STORM®	Denver, CO	39-3/8" x 13-1/4"
TruDefinition® Duration® MAX™	Compton, CA	39-3/8" x 13-1/4"
TruDefinition® Duration® FLEX™	Denver, CO; Summit, IL	39-3/8" x 13-1/4"
TruDefinition® WeatherGuard® HP	Memphis, TN	39-3/8" x 13-1/4"
Berkshire®	Minneapolis, MN	38" x 18-3/4"
Woodcrest®	Compton, CA	40" x 14-1/4"
Woodmoor®	Compton, CA	40" x 14-1/4"



Accessory (hip and ridge): Prefabricated hip and ridge shingles.

Product:	Factory IDs:	Dimensions:
ProEdge®	Atlanta, GA; Denver, CO; Irving, TX; Medina, OH Portland, OR	12" x 12"
ImpactRidge™ Hip & Ridge Shingles	Denver, CO; Summit, IL	12" x 12"
RIZERidge® Hip and Ridge	Houston, TX	12" x 12"
DuraRidge™ Hip and Ridge Shingles	Minneapolis, MN	10 ⁻⁵ / ₈ " x 12"
Berkshire® Hip & Ridge Shingles	Minneapolis, MN	10 ⁻⁵ / ₈ " x 12"
WeatherGuard® HP Hip & Ridge	Memphis, TN	12" x 12"

Accessory (starter): Prefabricated starter course shingles.

Product:	Factory IDs:	Dimensions:
Starter Strip Plus	Houston, TX; Medina, OH; Minneapolis, MN; Portland, OR	7 ⁻³ / ₄ " x 39 ⁻³ / ₈ "
Tri-Built Shingle Starter	Houston, TX; Medina, OH Minneapolis, MN; Portland, OR	7 ⁻³ / ₄ " x 39 ⁻³ / ₈ "
SRS TopShield Starter Shingle	Houston, TX; Medina, OH; Minneapolis, MN; Portland, OR	7 ⁻³ / ₄ " x 39 ⁻³ / ₈ "
WoodStart® Starter Shingle	Compton, CA	13 ⁻³ / ₈ " x 40"

Fire Classification:

When installed on new construction in accordance with this report and the OWENS CORNING® installation instructions, the OWENS CORNING® asphalt shingles are a Class A fire classification roof covering in accordance with ASTM E108 and/or ANSI/UL790 and qualify for use under the following code:

- 2021, 2018, 2015, 2012, and 2009 IBC Section 1505.1
- 2021, 2018, 2015, 2012, and 2009 IRC Section R902.1

When the shingles are installed over existing roof coverings, the fire classification is maintained.

Wind Resistance:

OWENS CORNING® asphalt shingles covered under this report have been tested for wind resistance in accordance with the following test methods:

Shingles tested in accordance with ASTM D3161 are classified as Class F and qualify for use under the exception to the following code:

- 2021 IBC Section 1504.2
- 2018 IBC Section 1507.2.3
- 2015 IBC Section 1507.2.8.1
- 2012 and 2009 IBC Section 1507.2.7.1
- 2021, 2018, 2015, 2012, and 2009 IRC Section R905.2.4.1

Shingles tested in accordance with ASTM D7158 are classified as Class H and qualify for use in locations as shown in the following code:

- 2021 IBC Table 1504.2
- 2015 and 2018 IBC Table 1504.1.1
- 2012 and 2009 IBC Table 1507.2.7.1
- 2021, 2018, 2015, 2012 and 2009 IRC Table R905.2.4.1

Where the maximum allowable stress design wind speed, V_{asd} , is 150 mph (67 m/s) or less in exposure category B or C (ASCE 7) and a maximum building height of 60 feet (18.3 m), installation must be in accordance with the following code as applicable:

- 2021 IBC Section 1507.2.5
- 2018 IBC Section 1507.2.6
- 2015, 2012, and 2009 IBC Section 1507.2.7
- 2021, 2018, 2015, 2012, and 2009 IRC Section R905.2

Physical Properties:

OWENS CORNING® asphalt shingles covered under this report have been tested for physical properties in accordance with ASTM D3462 and qualify for use under the following code:

- 2021 and 2018 IBC Section 1507.2.4
- 2015, 2012, and 2009 IBC Section 1507.2.5
- 2021, 2018, 2015, 2012, and 2009 IRC Section R905.2.4

Impact Resistance:

OWENS CORNING® TruDefinition® WeatherGuard® HP, TruDefinition® Duration® STORM, TruDefinition® Duration® FLEX, ImpactRidge™ Hip & Ridge Shingles, and WeatherGuard HP Hip & Ridge covered under this report have been tested for impact resistance in accordance with UL 2218 Class 4.

Shingles have also been evaluated in accordance with ICC-ES Acceptance Criteria, AC438.



INSTALLATION – GENERAL

OWENS CORNING® asphalt shingles must be installed in accordance with the applicable code, this report, and the manufacturer’s published installation instructions, which must be available at all times on the jobsite during installation. Minimum roof slopes must be 2:12 (16.67% slope or 9°) for the three-tab shingles and for the laminated shingles. The shingles must be installed in accordance with the following code as applicable, except as noted in this report:

- 2021, 2018, 2015, 2012, and 2009 *IBC* Section 1507.2
- 2021, 2018, 2015, 2012, and 2009 *IRC* Section R905.2

Deck:

The roof deck must be code-complying, minimum $\frac{3}{8}$ inch thick (9.5 mm), exterior plywood complying with DOC PS-1; OSB rated sheathing complying with DOC PS-2; or solid sheathing using minimum nominal 1 by 6 lumber.

Underlayment and Ice Barriers:

Underlayment must comply with ASTM D226, ASTM D4869, or ASTM D6757 as specified in the following code:

- 2021, 2018, 2015, 2012, and 2009 *IBC* Section 1507.2.3
- 2021, 2018, 2015, 2012, and 2009 *IRC* Section R905.2.3

When used as an underlayment under shingles described in this report, self-adhering polymer modified bitumen sheet must comply with ASTM D1970.

For roof slopes greater than 4:12 (33.33% slope or 18°), the roof deck must be covered with minimum one layer of underlayment. Roofs having slopes between 2:12 (16.67% slope or 9°) and 4:12 (33.33% slope or 18°) require minimum two layers of underlayment. Underlayment application must be in accordance with the following code as applicable:

- 2021, and 2018 *IBC* Section 1507.2.3
- 2015, 2012, and 2009 *IBC* Section 1507.2.8
- 2021, 2018, and 2015 *IRC* Section R905.2.3
- 2012, and 2009 *IRC* Section R905.2.7

In areas where there has been a history of ice forming along the eaves, causing a backup of water, as indicated by Table R301.2 (1), an ice barrier must be provided in accordance with the following code as applicable:

- 2021 and 2018 *IBC* Section 1507.2.7
- 2015, 2012, and 2009 *IBC* Section 1507.2.8.2
- 2021, 2018, and 2015 *IRC* Section R905.2.7
- 2012 and 2009 *IRC* Section R905.2.7.1

Fasteners:

Fasteners must comply with ASTM F1667 and be minimum No. 12 gage (0.105 inch), $\frac{3}{8}$ inch diameter head, galvanized, stainless steel, aluminum or copper corrosion-resistance nails. Fasteners must penetrate into the deck minimum $\frac{3}{4}$ inch, or through the deck, where the deck is less than $\frac{3}{4}$ inch thick.

Asphalt Cement:

Asphalt cement must comply with ASTM D4586.

Sealant:

Sealant must comply with ASTM C920.

Valley Construction and Other Flashing:

Valleys must consist of woven, open valley or closed-cut construction and must be flashed in accordance with the following code as applicable:

- 2021 and 2018 *IBC* Section 1507.2.8.2
- 2015, 2012, and 2009 *IBC* Section 1507.2.9.2
- 2021, 2018, 2015, 2012, and 2009 *IRC* Section R905.2.8.2

Other flashings must comply with the following code as applicable:

- 2021 and 2018 *IBC* Section 1503.2 and 1507.2.8
- 2015, 2012, and 2009 *IBC* Section 1503.2 and 1507.2.9
- 2021, 2018, 2015 2012, and 2009 *IRC* Section R903.2 and 905.2.8

Reroofing:

Prior to the reroofing, hip and ridge coverings must be removed. The existing asphalt shingle roof covering must be inspected in accordance with the provisions and limitations of the following codes as applicable:

- 2021 *IBC* Section 1512
- 2018 and 2015 *IBC* Section 1511
- 2012 and 2009 *IBC* Section 1510
- 2021, 2018, and 2015 *IRC* Section R908
- 2012 and 2009 *IRC* Section R907

The shingles must be installed in accordance with this report. Fasteners must be of sufficient length to penetrate $\frac{3}{4}$ inch into the deck, or through the deck where the deck is less than $\frac{3}{4}$ inch thick.



INSTALLATION – ASPHALT SHINGLES

Starter Shingles:

A starter course of **Starter Strip Plus**, **Tri-Built Shingle Starter**, **SRS TopShield Starter Shingle**, or **Woodstart® Starter Shingle** must be attached to the eave edge using fasteners approved by this report, located 1-1/2 to 3 inches from the eave edge and spaced 8 to 10 inches apart, for a total of five fasteners per shingle. The starter strip must overhang the eaves and rake edges by 1/4 to 3/4 inch. See Figures 1 and 2.

If self-sealing three-tab shingles are used, remove the exposed tab portion and install with factory-applied sealant adjacent to the eaves.

Figure 1 – Starter Strip Plus, Tri-Built Shingle Starter, and SRS TopShield Starter Shingle

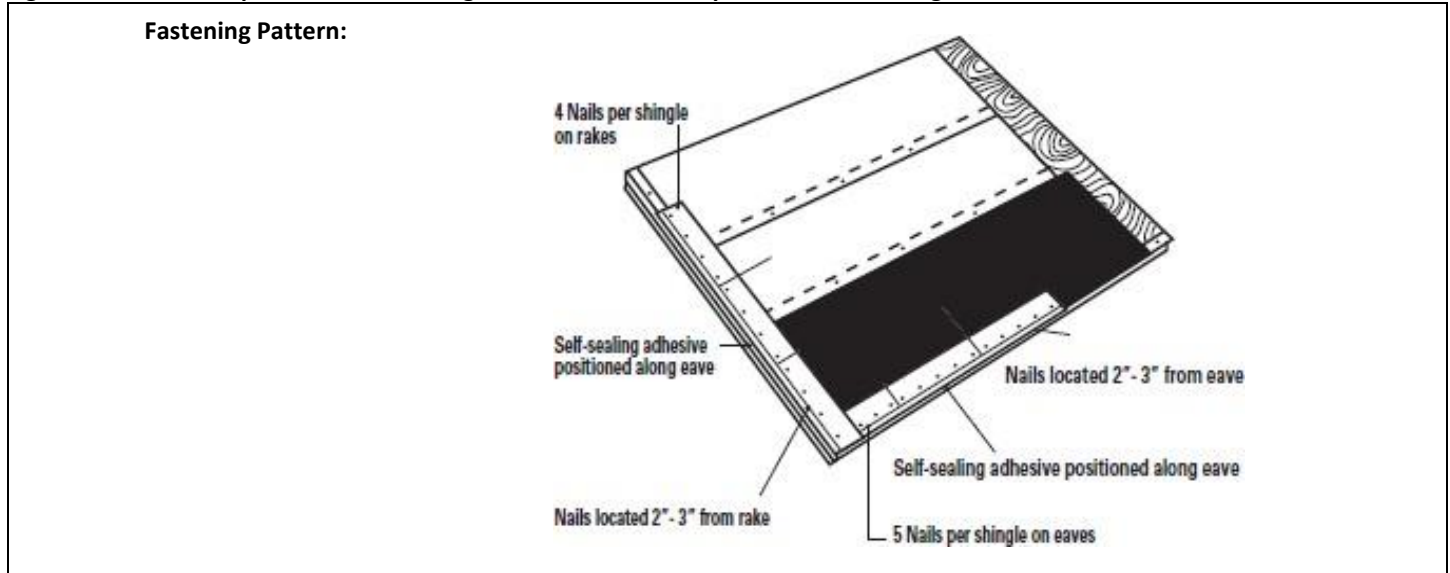
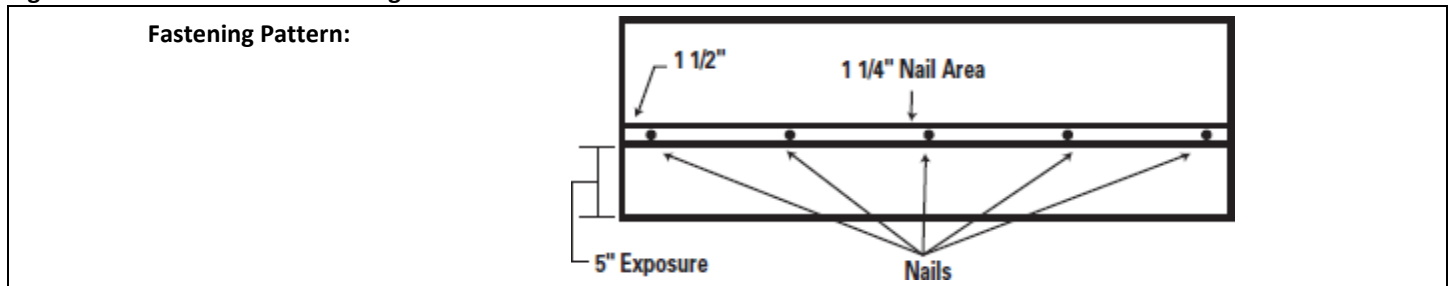

Figure 2 – WoodStart® Starter Shingle





Field Shingles:

Supreme®: For roof slopes of 2:12 up to 21:12 (16.67% or 9° up to 175% or 60°), use a minimum of four (4) fasteners per shingle; a minimum of six (6) fasteners per shingle may optionally be used in high velocity wind zones. For roof slopes over 21:12 (175% or 60°), use a minimum of six (6) fasteners per shingle and 1 inch diameter spots of asphalt cement placed under each corner (1 to 2 inches from each end) of each tab (two spots per tab). See Figure 3 for fastener spacing. Fasteners must be located 5/8 inch above the tab cut-out and below the sealant strip; do not drive fasteners into or above sealant strip. Maximum exposure to the weather must be $5 \pm 1/8$ inches for standard-sized shingles or $5\text{-}5/8 \pm 1/8$ inches for metric-sized shingles.

The first course of field shingles must be installed over a starter course. Apply first course starting with a full shingle, aligned even with starter. Subsequent shingle courses must be installed with vertical joint offsets from adjacent courses. For standard-sized three-tab shingles, 6 inch offsets are suggested, but repeatable patterns greater than 4 inches are permitted. For metric-sized three-tab shingles, $6\text{-}9/16$ inch (167 mm) offsets are suggested, but repeatable patterns greater than 4 inches (102 mm) are permitted.

Caution must be exercised to assure that end joints are minimum 2 inches from a fastener in the shingle below and that side laps are minimum 4 inches in succeeding courses.

Note: In colder climates or wind regions where it is questionable whether the thermal-sealing adhesive will activate to seal the shingles, the shingles can be hand-sealed. A 1 inch diameter spot of asphalt cement should be placed under the corner (1 to 2 inches from each end) of each tab (two spots per tab).

Figure 3 - Supreme®

<p>Four (4) Fastener Pattern: For standard-sized shingle</p>	<p style="text-align: center;">5" Exposure</p>
<p>Four (4) Fastener Pattern: For metric-sized shingle</p>	<p style="text-align: center;">5 5/8" Exposure</p>
<p>Six (6) Fastener Pattern:</p>	



Oakridge® and TruDefinition® Oakridge®: For roof slopes of 2:12 up to 21:12 (16.67% or 9° up to 175% or 60°), use a minimum of four (4) fasteners per shingle; a minimum of six (6) fasteners per shingle may optionally be used in high velocity wind zones. For roof slopes over 21:12 (175% or 60°), use a minimum of six (6) fasteners per shingle and four (4) 1 inch diameter spots of asphalt cement per shingle (2 inches up from the bottom edge). See Figure 4 for fastener spacing. Fasteners must be located 6-1/8 inches above the butt edge of the shingles. Maximum exposure to the weather must be 5-5/8 inches.

The first course of field shingles must be installed over a starter course. Apply first course starting with a full shingle, aligned even with starter. Subsequent shingle courses must be installed with vertical joint offsets from adjacent courses. 6-1/2 inch offsets are suggested, but repeatable patterns greater than 4 inches are permitted.

Caution must be exercised to assure that end joints are minimum 2 inches from a fastener in the shingle below and that side laps are minimum 4 inches in succeeding courses.

Note: In colder climates or wind regions where it is questionable whether the thermal-sealing adhesive will activate to seal the shingles, the shingles can be hand-sealed. Four (4) 1 inch diameter spots of asphalt cement should be placed under the exposed portion of the shingle, spaced 1 to 2 inches from each end of the shingle with two spots evenly spaced in between.

Figure 4 - Oakridge® and TruDefinition® Oakridge®

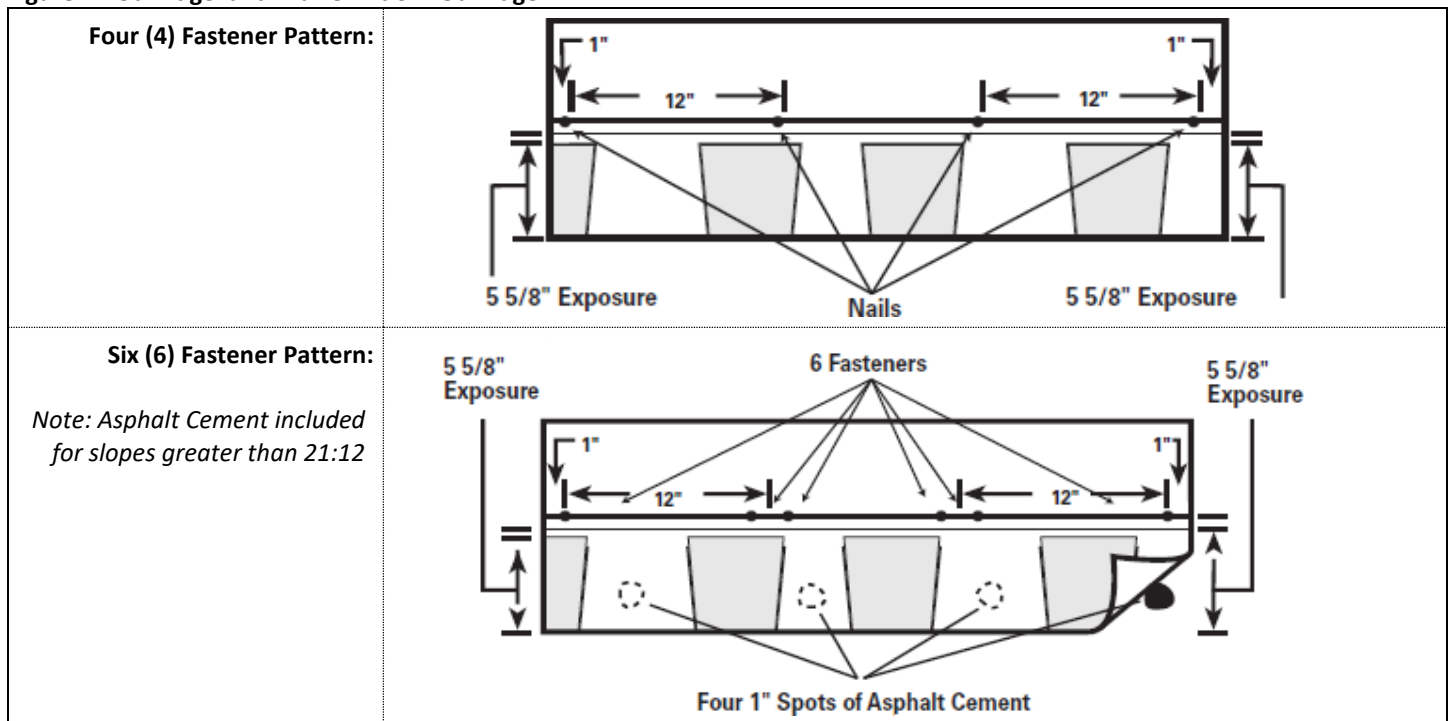



Duration® Premium, Duration® Premium COOL, TruDefinition® Duration®, TruDefinition® Duration® COOL, TruDefinition® Duration® STORM®, TruDefinition® Duration® MAX, TruDefinition® Duration® FLEX: For roof slopes of 2:12 up to 21:12 (16.67% or 9° up to 175% or 60°), use a minimum of four (4) fasteners per shingle; a minimum of six (6) fasteners per shingle may optionally be used in high velocity wind zones. For roof slopes over 21:12 (175% or 60°), use a minimum of six (6) fasteners per shingle and four (4) 1 inch diameter spots of asphalt plastic cement per shingle (2 inches up from the bottom edge). See Figure 5 for fastener spacing. Fasteners must be located 6-1/8 inches above the butt edge of the shingles (center of the SureNail® fastening area for Duration® products). Maximum exposure to the weather must be 5-5/8" ± 1/8 inch.

The first course of field shingles must be installed over a starter course. Apply first course starting with a full shingle, aligned even with starter. Subsequent shingle courses must be installed with vertical joint offsets from adjacent courses. 6-1/2 inch offsets are suggested, but repeatable patterns greater than 4 inches are permitted.

Caution must be exercised to assure that end joints are minimum 2 inches from a fastener in the shingle below and that side laps are minimum 4 inches in succeeding courses.

Note: In colder climates or wind regions where it is questionable whether the thermal-sealing adhesive will activate to seal the shingles, the shingles can be hand-sealed. Four (4) 1 inch diameter spots of asphalt cement should be placed under the exposed portion of the shingle, spaced 1 to 2 inches from each end of the shingle with two spots evenly spaced in between.

Figure 5 - Duration® Premium, Duration® Premium COOL, TruDefinition® Duration®, TruDefinition® Duration® COOL, TruDefinition® Duration® STORM®, TruDefinition® Duration® MAX, and TruDefinition® Duration® FLEX

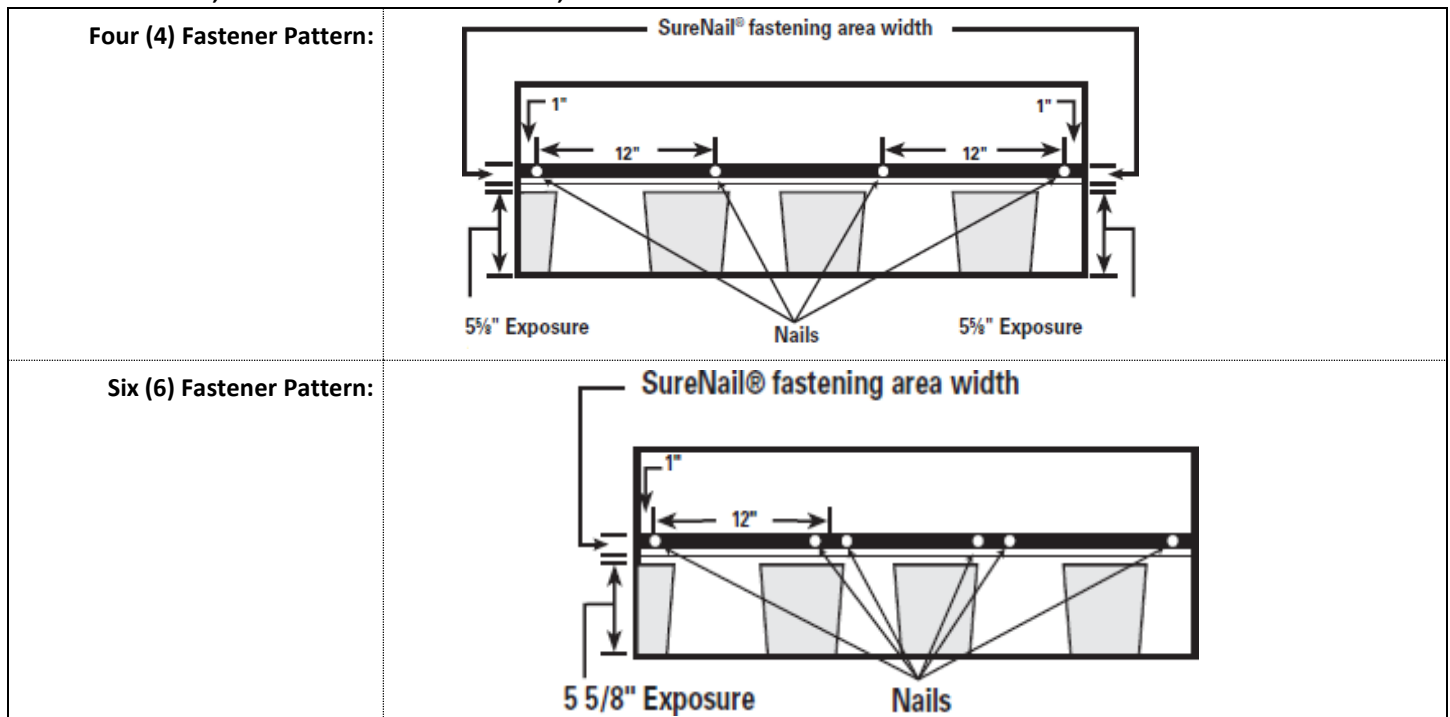



TruDefinition® WeatherGuard® HP: For roof slopes of 2:12 up to 21:12 (16.67% or 9° up to 175% or 60°), use a minimum of four (4) fasteners per shingle; a minimum of six (6) fasteners per shingle may optionally be used in high velocity wind zones. For roof slopes over 21:12 (175% or 60°), use a minimum of six (6) fasteners per shingle and four (4) 1 inch diameter spots of asphalt cement per shingle (2 inches up from the bottom edge). See Figure 6 for fastener spacing. Fasteners must be located 6-1/8 inches above the butt edge of the shingles and secure both layers of the shingle. Maximum exposure to the weather must be 5-5/8 inches ± 1/8 inches.

The first course of field shingles must be installed over a starter course. Apply first course starting with a full shingle, aligned even with starter. Subsequent shingle courses must be installed with vertical joint offsets from adjacent courses. 6-1/2 inch offsets are suggested, but repeatable patterns greater than 4 inches are permitted.

Note: In colder climates or wind regions where it is questionable whether the thermal-sealing adhesive will activate to seal the shingles, the shingles can be hand-sealed. Four (4) 1 inch diameter spots of asphalt cement should be placed under the exposed portion of the shingle, spaced 1 to 2 inches from each end of the shingle with two spots evenly spaced in between.

Figure 6 - TruDefinition® WeatherGuard® HP

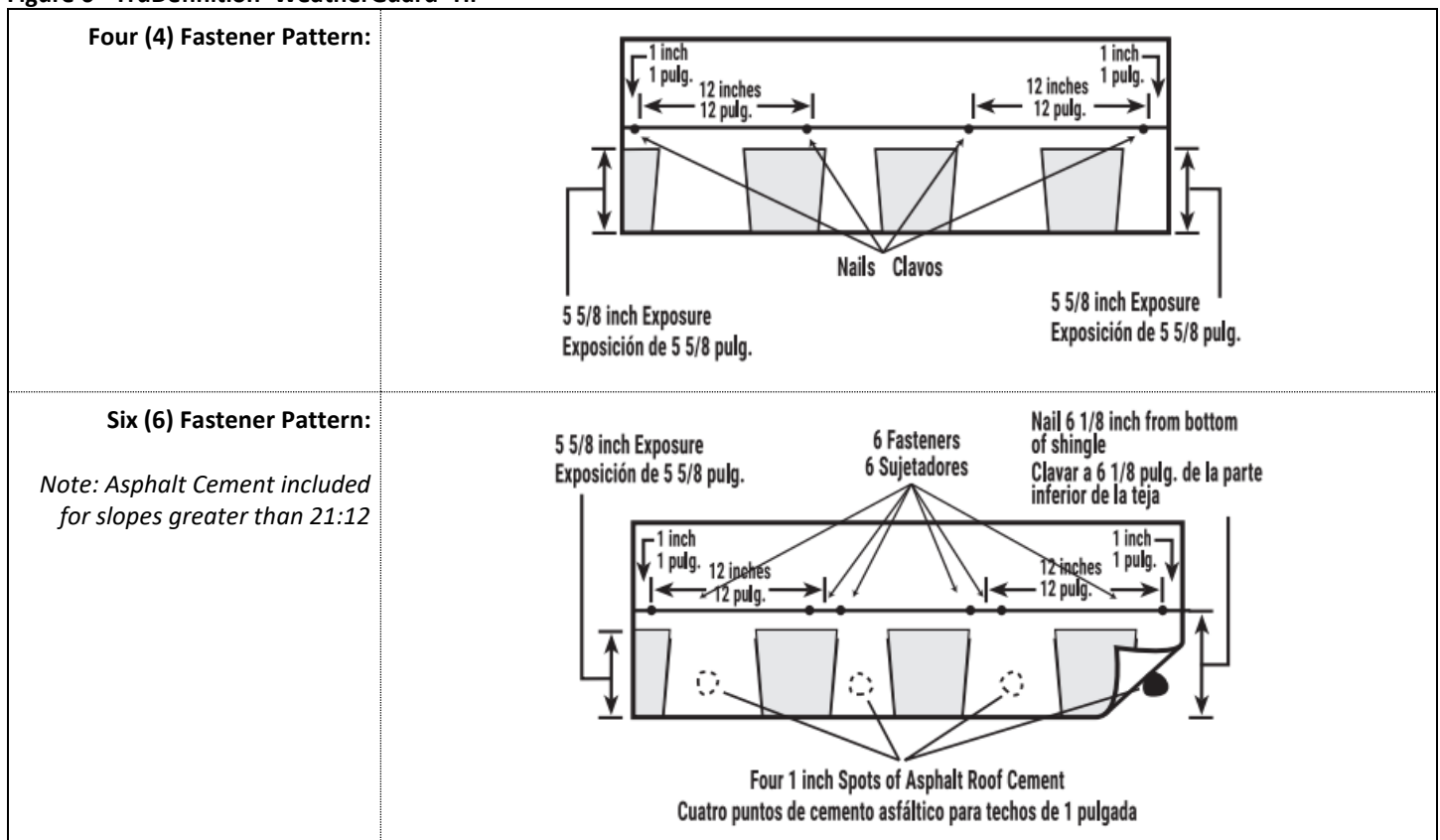



Berkshire®: For roof slopes of 2:12 up to 21:12 (16.67% or 9° up to 175% or 60°), use a minimum of five (5) fasteners per shingle; a minimum of six (6) fasteners per shingle may optionally be used in high velocity wind zones. For roof slopes over 21:12 (175% or 60°), use a minimum of six (6) fasteners per shingle and 1 inch diameter spots of asphalt cement placed under each tab (centered across tab width and 2 inches up from bottom edge of shingle). See Figure 7 for fastener spacing. Fasteners must be located $\frac{5}{8}$ inch above the tab cut-out and below the sealant strip; do not drive fasteners into or above sealant strip. Maximum exposure to the weather must be $8\text{-}\frac{3}{8} \pm \frac{1}{8}$ inch.

Shingles are applied in a single-column, vertical-racking method. The first course of field shingles must be installed over a starter course. Apply first course with a full shingle, aligned even with starter. Apply second course with a $4\text{-}\frac{3}{4}$ inch offset. Thereafter, alternate shingle courses; odd-numbered courses start with a full shingle and even-numbered courses start with a $4\text{-}\frac{3}{4}$ inch offset.

Caution must be exercised to assure that end joints are minimum 2 inches from a fastener in the shingle below and that side laps are minimum 4 inches in succeeding courses.

Note: In colder climates or wind regions where it is questionable whether the thermal-sealing adhesive will activate to seal the shingles, the shingles can be hand-sealed. A 1 inch diameter spot of asphalt cement should be placed under the corner 1 to 2 inches from each end of each tab (two spots per tab).

Figure 7 - Berkshire®

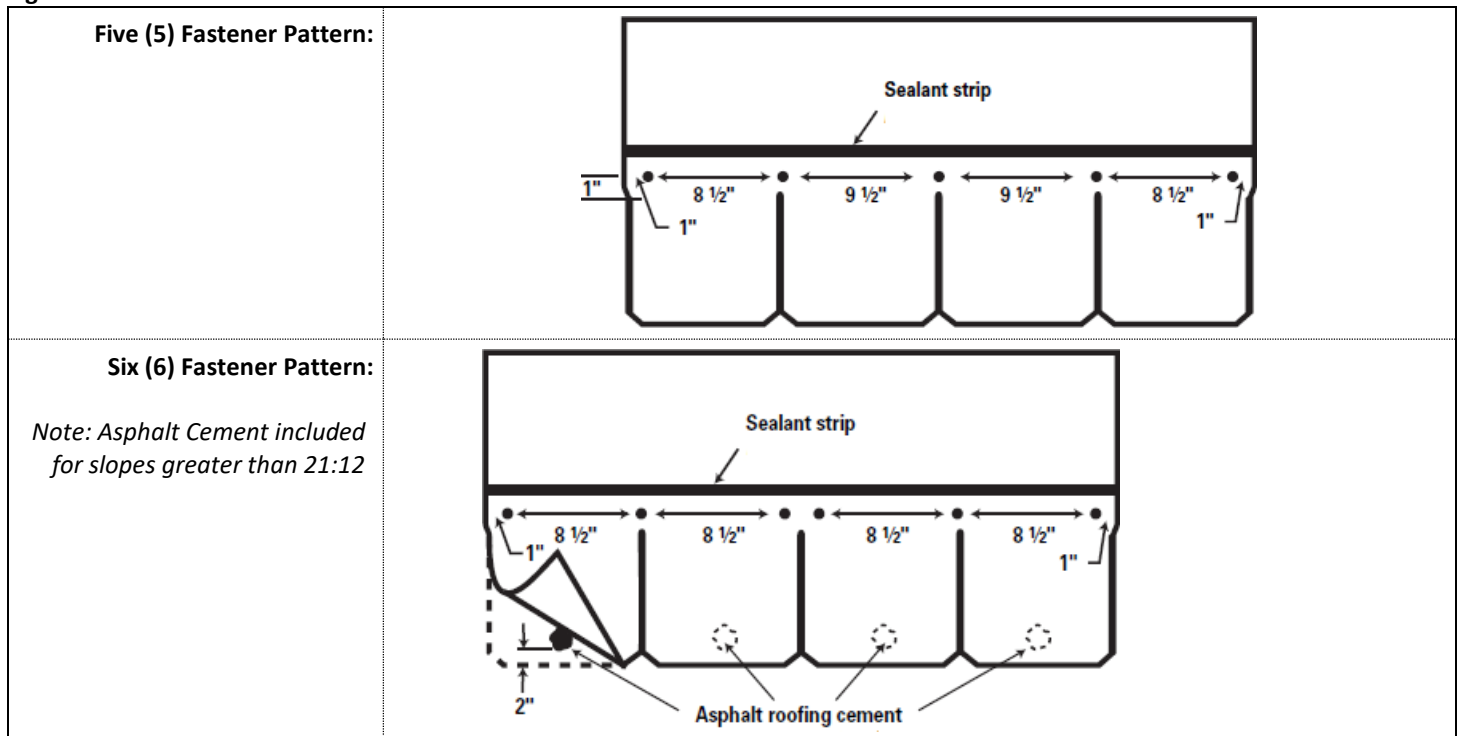



Woodcrest® and Woodmoor®: For roof slopes of 2:12 up to 21:12 (16.67% or 9° up to 175% or 60°), use a minimum of five (5) fasteners per shingle; a minimum of six (6) fasteners per shingle may optionally be used in high velocity wind zones. For roof slopes over 21:12 (175% or 60°), use a minimum of nine (9) fasteners per shingle and 1 inch diameter spots of asphalt cement placed under each tab (centered across tab width and 2 inches up from bottom edge of shingle). See Figure 8 for fastener spacing. Maximum exposure to the weather must be $4 \pm \frac{1}{8}$ inches.

Shingles are applied in either a 5 inch & 5 inch or a 5 inch & 15 inch offset method. The first course of field shingles must be installed over a starter course. Apply first course with a full shingle, aligned even with starter. Subsequent shingle courses must be installed with vertical joint offsets from adjacent courses. For 5 inch & 5 inch offset method, apply subsequent courses with a 5 inch offset. For 5 inch & 15 inch offset method, apply second course with a 5 inch offset (cut 5 inches from a full shingle); apply third course with a 15 inch offset (cut 20 inches from a full shingle); apply fourth course with a 5 inch offset (cut 25 inches from a full shingle); repeat application pattern thereafter.

Caution must be exercised to assure that end joints are minimum 2 inches from a fastener in the shingle below and that side laps are minimum 4 inches in succeeding courses.

Note: In colder climates or wind regions where it is questionable whether the thermal-sealing adhesive will activate to seal the shingles, the shingles can be hand-sealed. A 1 inch diameter spot of asphalt cement should be placed under the corner 1 to 2 inches from each end of each tab (two spots per tab).

Figure 8 - Woodcrest® and Woodmoor®

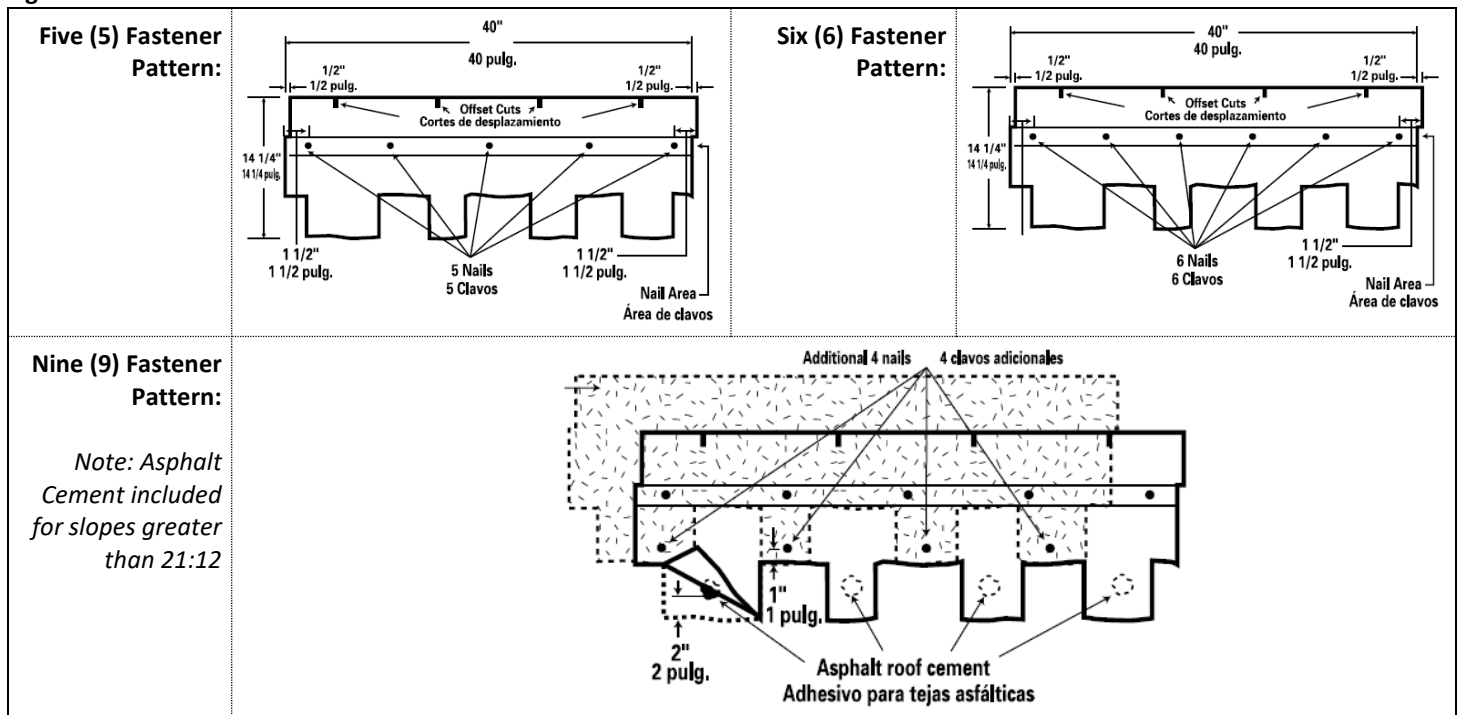



Hip and Ridge Shingles:

Complete field shingle application before applying hip and ridge shingles. Hip shingles must be applied before applying ridge shingles. Arrange hip and ridge shingles along center line so that both halves of the laminated piece fall on opposite sides of the hip or ridge. When finishing ridge, leave no headlap or laminated portion exposed; cover exposed fasteners with asphalt cement.

ProEdge®: Use four (4) fasteners per shingle. Fasten each shingle with two (2) fasteners on each side, placed 6-1/4 inch from the exposed end and 1 inch and 2 inch in from the side edge. See Figure 9 for fastener spacing. Fasteners must be located above the sealant strip; do not drive fasteners into sealant strip. Maximum exposure to the weather must be 6 inches.

Figure 9 - ProEdge®

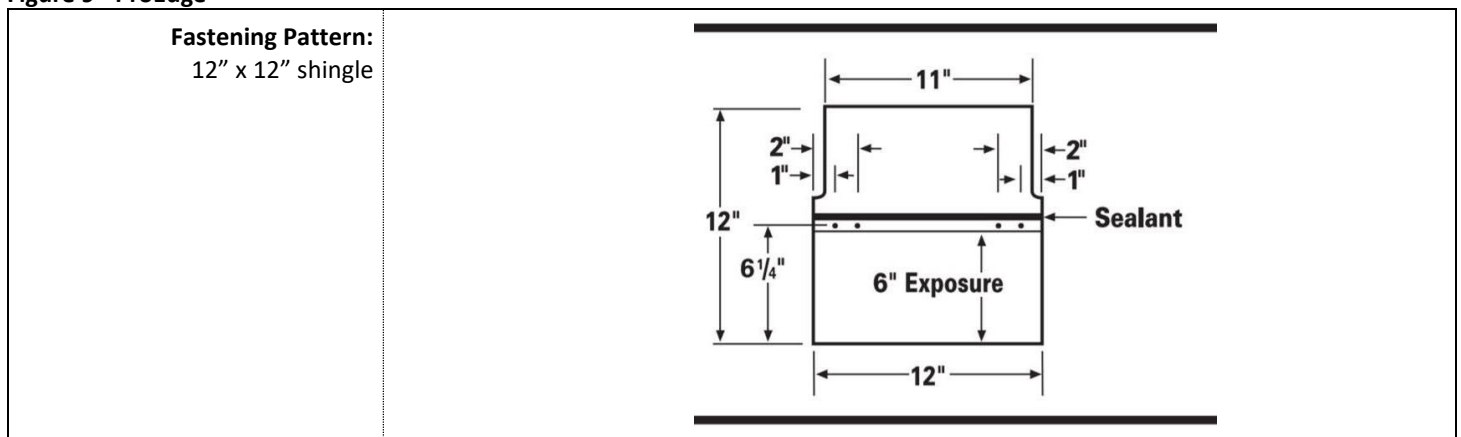

ImpactRidge™: Use four (4) fasteners per shingle. Fasten each shingle with two (2) fasteners on each side, placed 6-1/4 inch from the exposed end and 1 inch and 2 inch in from the side edge. See Figure 10 for fastener spacing. Fasteners must be located below the sealant strip; do not drive fasteners into sealant strip. Maximum exposure to the weather must be 6 inches.

Figure 10 – ImpactRidge™

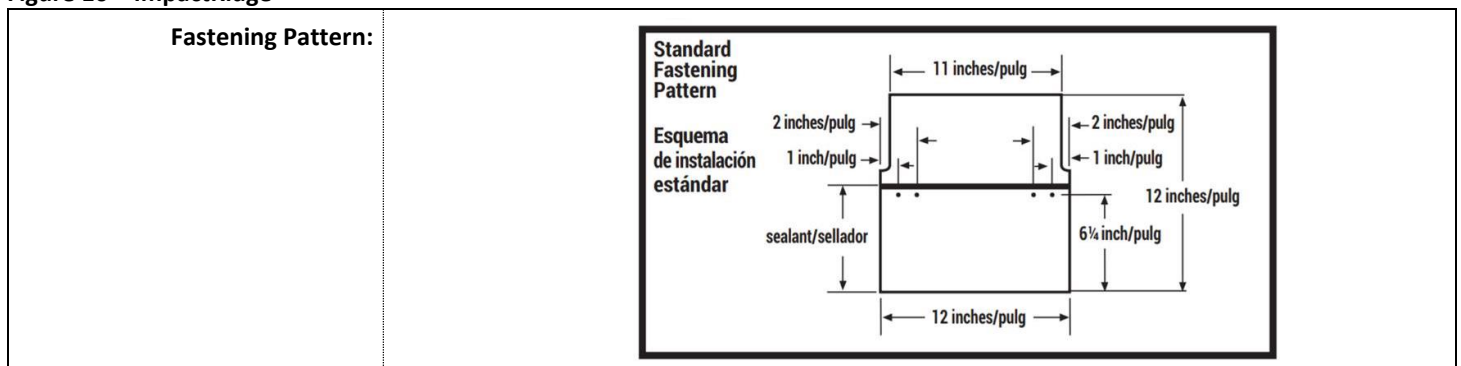



RIZERidge® Hip and Ridge Shingles: Shingles contain perforation lines to establish a foldable design and create a multi-layered dimension. Use four (4) fasteners and two (2) beads of sealant per shingle. Fasten each shingle with two (2) fasteners on each side, placed 7 inch from the exposed end and 1 inch and 2 inch in from the side edge. On each side and between the fasteners at approximately 1-1/2 inch in from the side edge, place a 1/4 inch wide by 2 inch long bead. See Figure 11 for fastener spacing and sealant application. Maximum exposure to the weather must be 6 inches.

Figure 11 - RIZERidge® Hip and Ridge Shingles

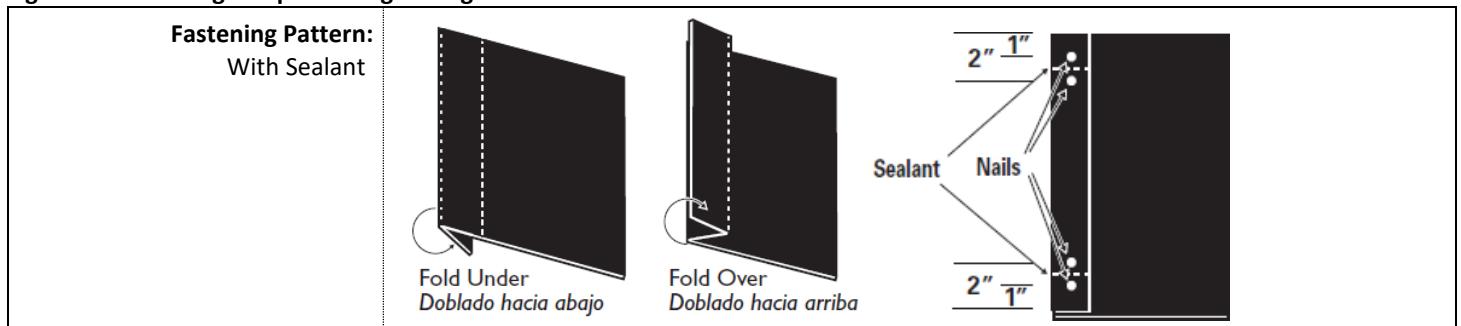

DuraRidge™ Hip and Ridge Shingles: Use two (2) fasteners per shingle. Fasten each shingle through the top laminated piece with one (1) fastener on each side, placed 9 inch from the exposed end and 1 inch in from the side edge. Fasteners must be located in the center of the SureNail® fastening area. See Figure 12 for fastener spacing. Maximum exposure to the weather must be 8 inches.

Figure 12 - DuraRidge™ Hip and Ridge Shingles

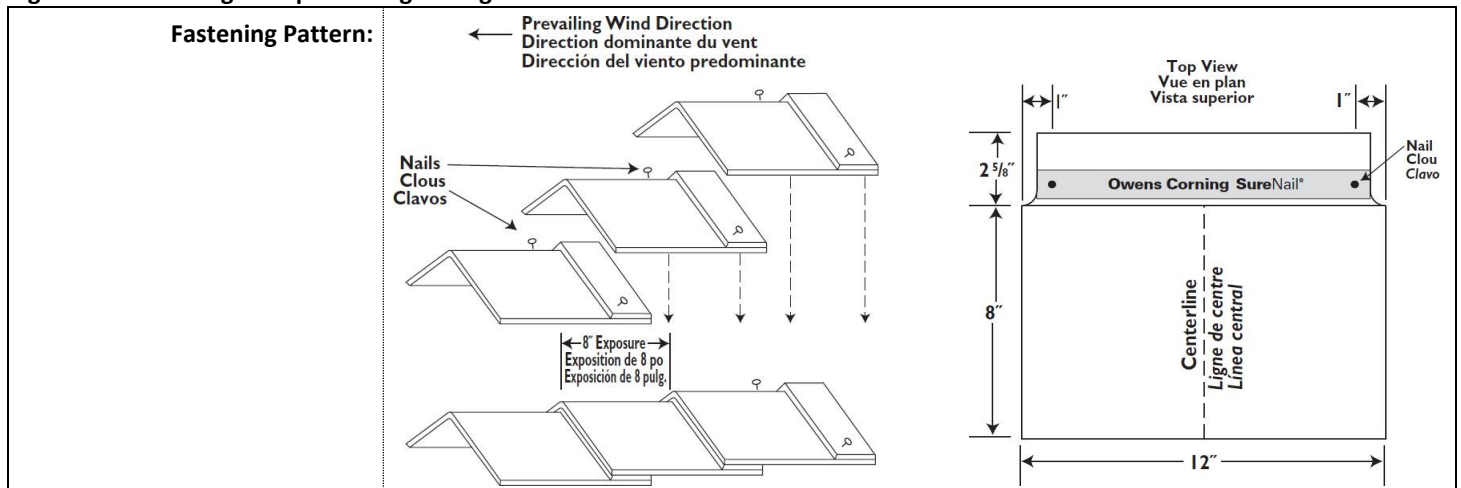



Berkshire® Hip and Ridge Shingles: Use two (2) fasteners per shingle. Fasten each shingle through the top laminated piece with one (1) fastener on each side, placed 9 inch from the exposed end and 1 inch in from the side edge. Fasteners must be located in the center of the SureNail® fastening area. See Figure 13 for fastener spacing. Maximum exposure to the weather must be 8 inches.

Figure 13 - Berkshire® Hip and Ridge Shingles

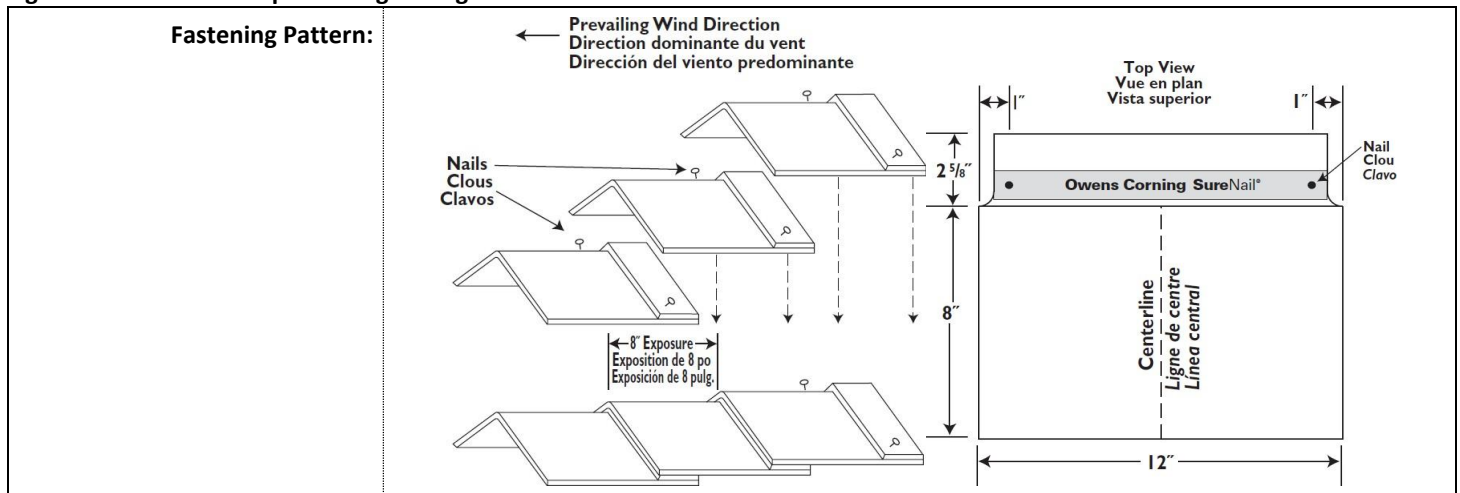

WeatherGuard® HP Hip and Ridge Shingles: Use four (4) fasteners per shingle. Fasten each shingle through the top laminated piece with two (2) fasteners on each side, placed 6 inch from the exposed end and 1 and 2 inches in from the side edge. See Figure 14 for fastener spacing. In high wind zones, apply a 1/4 inch wide by 5 inch long bead of ASTM C920 elastomeric sealant starting 1 inch from the edge to each side of the shingle. Maximum exposure to the weather must be 5 inches.

Figure 14 – WeatherGuard® HP Hip and Ridge Shingles

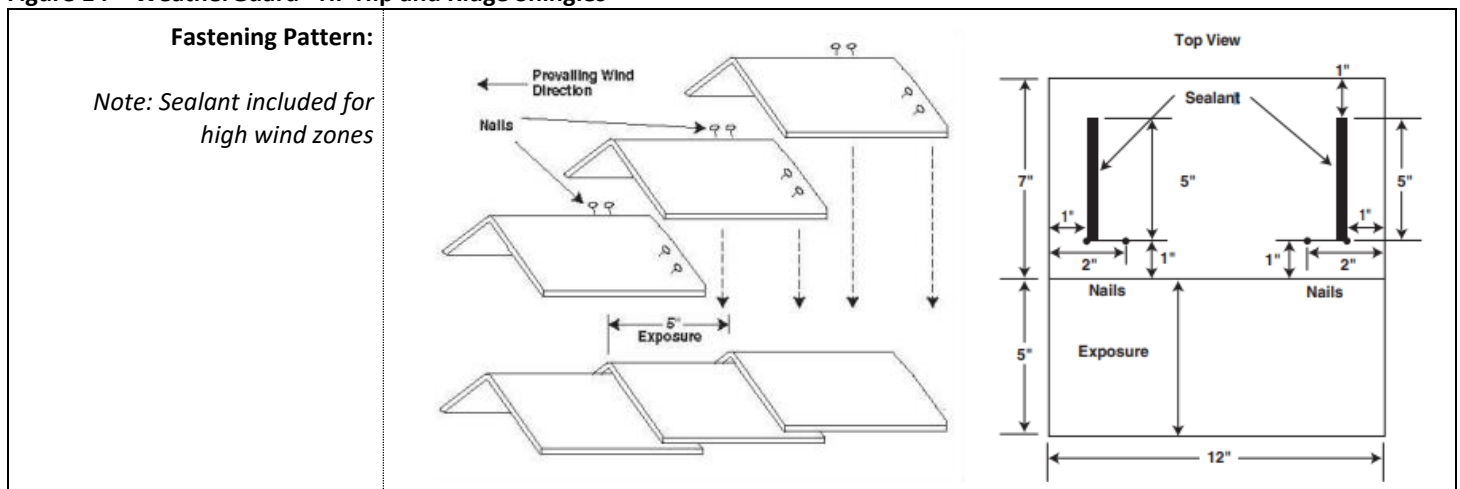



CONDITIONS OF USE & IDENTIFICATION

The OWENS CORNING® Asphalt Shingles described in this report comply with, or are suitable alternatives to, the codes listed in this report, subject to the following conditions:

- The products as well as the installation methods must be in compliance with the applicable code, this report, and the installation instruction provided by the manufacturer. If the manufacturer's installation instructions differ from what is listed in this report, this report governs.
- This report does not supersede the local jurisdiction regulations and the final approval of the building products, materials, or systems in this report is the responsibility of the authorities having jurisdiction.
- This report is only valid if the product(s) and/or the referenced documentation/codes related to the products do not change. If there is a change in product(s) and/or the referenced documentation/codes related to the products, PRI Construction Materials Technologies, LLC must be informed and further action may be necessary to revalidate this report.
- This report, in its entirety, must be available at job sites upon request by the user or for inspection by the Building Official. A copy of this report in full shall be provided by the manufacturer or its distributors.
- The products are identified by marks bearing the report holder's name, the manufacture location, the product name, and the Seal of PRI Validation Program for Building Materials. The Seal shall indicate, at a minimum, the following:
 - a. ASTM E108 – Class A
 - b. ASTM D3161 – Class F
 - c. ASTM D7158 – Class H
 - d. ASTM D3462
 - e. ICC-ES Acceptance Criteria, AC438
- The products are manufactured at the locations listed in this report and are manufactured under a quality control program with surveillance and/or inspections by PRI Construction Materials Technologies, LLC.
- This report is a supplement to product certification. The products listed herein must be certified separately under the PRI Validation Program for Building Products. This report alone is not a product certification and requires separate product certification under the PRI Validation Program for Building Products to be valid.
- The current status of this report as well as a directory of certified products, including supplemental PRI Evaluation Reports, can be found at pri-group.com.

© 2019 PRI Construction Materials Technologies, LLC

This PRI Evaluation Report is for the exclusive use by the Client with which a signed agreement was made with PRI Construction Materials Technologies, LLC. PRI Construction Materials Technologies, LLC is only responsible and/or liable for the terms and conditions outlined in that signed agreement. Only the Client has authority to distribute or authorize distribution of the report in its entirety and they shall not do so in a misleading manner. Any loss, expense, or damage caused by the use of this report to any party, other than the Client in accordance with the agreement, is not the responsibility or fault of PRI Construction Materials Technologies, LLC. PRI Construction Materials Technologies, LLC has no financial interest, nor does it have intent to acquire financial interest, in the manufacture or the distribution of the product(s) listed in this report. PRI Construction Materials Technologies, LLC is not under the ownership, operation, or control of the manufacturer or the distributor of the product(s) listed in this report. PRI Construction Materials Technologies, LLC does not guarantee any representations or warranties on any product(s) or subjects contained in this report. This PRI Evaluation Report is an evaluation of building code and is in no way an endorsement or a recommendation for use for the product(s) listed within. All data utilized in support of this report comes from accredited laboratories that show compliance with ISO/IEC Standard 17025 by the International Accreditation Service (IAS) or by any other accreditation body that is a signatory to the International Laboratory Accreditation Cooperation (ILAC) Mutual Recognition Arrangement (MRA). The accuracy of any data that comes from an accredited laboratory that is not PRI Construction Materials Technologies, LLC is the responsibility of the publishing laboratory alone; PRI Construction Materials Technologies, LLC does not accept any responsibility for the accuracy of this data.