

Product Data Sheet



Type I-HP

Type II-HP

Description

Fiberglas™ Thermal Insulating Wool (TIW) Types I-HP and II-HP Insulations are off-white, noncombustible wool with resilient, inorganic glass fibers bonded with a thermosetting resin. TIW Type I-HP Insulation is available in rolls; TIW Type II-HP Insulation comes in batts.

Key Features

- Excellent thermal performance contributes to lower fuel costs due to reduced heat loss.
- Easy to handle and install. The insulation is easily impaled over welded studs or pins, or may be held in place with wire ties, metal lath or lagging.
- There is no tendency for pin-hole elongation under vibration situations, a frequent source of heat leaks in heavier products.
- Large batts or blankets cover greater areas quickly, eliminating tedious block-by-block hand layup and drilling for studs in hard insulations.

Physical Property Data

Property	Test Method	Type I-HP Value	Type II-HP Value
Equipment Operating Temperature Range ¹	ASTM C411	Up to 1,000°F (538°C)	
Nominal Density	ASTM C167	1.0 pcf (16 kg/m ³)	2.5 pcf (40 kg/m ³)
Shot Content	ASTM C1335	Negligible	
Water Vapor Sorption	ASTM C1104	< 2.0% by weight at 120°F (49°C), 95% R.H.	
Surface Burning Characteristics	UL 723, ASTM E84 or CAN/ULC-S102		
Flame Spread ²		25	
Smoke Developed		50	

1. Maximum allowable thickness at 1,000°F (538°C): Type I-HP - 8.5" (216mm); Type II-HP - 6" (152mm).
2. The surface burning characteristics of these products have been determined in accordance with UL 723, ASTM E84 or CAN/ULC-S102. This standard should be used to measure and describe the properties of materials, products or assemblies in response to heat and flame under controlled laboratory conditions and should not be used to describe or appraise the fire hazard or fire risk of materials, products or assemblies under actual fire conditions. However, results of this test may be used as elements of a fire risk assessment which takes into account all of the factors which are pertinent to an assessment of the fire hazard of a particular end use. Values are reported to the nearest 5 rating.

Availability

Sizes	TIW, Type I-HP (Rolls)		
Widths, in. (m)	Thickness, in. (mm)	Length, ft. (m)	No. of layers
24 (0.6)	1.0 (25)	87 (26.5)	2 layers
36 (0.9)	1.5 (38)	58 (26.5)	2 layers
48 (1.2)	2.0 (51)	87 (26.5)	1 layer
	3.0 (76)	58 (17.7)	1 layer
	4.0 (102)	44 (13.4)	1 layer

TIW, Type II-HP (Batts)

Thickness, in. (mm)	Widths, in. (m) x length, in. (m)
1 (25) - 4 (102) ½ (13) increments	24 x 48 (0.6 x 1.2)
	36 x 48 (0.9 x 1.2)

- Can be used in direct contact with steel, copper and aluminum without corrosive effects.

Product Applications

Fiberglas™ TIW Type I-HP Insulation is used in applications up to 1,000°F (538°C) at maximum recommended thickness requiring a lightweight insulation, such as that used in panel systems, flexible wrap, industrial ovens or surfaces having irregularities. Its low compressive strength does not make it suitable for use as a base wool for metal mesh blankets.

Installation

Fiberglas™ TIW Type II-HP Insulation is especially suitable for use in metal mesh blankets and for use on boilers, vessels and many other types of industrial equipment operating at temperatures up to 1,000°F (538°C) at maximum recommended thickness. It may also be used in panel systems for precipitators, ducts and breechings where more compressive resistance than Fiberglas™ TIW Type I-HP Insulation is needed.

Fiberglas™ TIW Types I-HP and II-HP Insulations can be installed directly on heated flat and curved



Fiberglas™ Thermal Insulating Wool (TIW) Types I-HP & II-HP Insulations

Thermal Conductivity

Product Data Sheet

surfaces by attaching with welded pins or studs and finishing with sheet metal or metal mesh and insulating cement, then canvassed and painted. Pins with speed washers or studs and nuts should be installed on 16" (400mm) (maximum) spacing and not more than 4" (100mm) from the edge of the insulation. The insulation is normally impaled over the pins or studs and the enclosing sheet metal or metal mesh secured to the same fasteners. Joints of the sheet metal finish are offset from joints of the insulation.

For temperatures over 400°F (204°C), good insulation practice suggests double layer application, with overlapping the layers regardless of insulation type. Single layer installation of any type of insulation material requires good workmanship to minimize heat loss and hot spots at insulation joints. Fiberglas™ TIW Types I-HP and II-HP Insulations may be installed in either single or multiple layers at all temperatures up to 1,000°F (538°C). Maximum allowable thicknesses at that temperature: TIW Type I-HP, 8½" (216mm); TIW Type II-HP, 6" (152mm).

Standards, Codes Compliance

- ASTM C553, Mineral Fiber Blanket Thermal Insulation, Types I, II, V – TIW Type I-HP; all types – TIW Type II-HP when specification Type VII is limited to 1,000°F maximum use temperature.
- ASTM C612, Mineral Fiber Block & Board Thermal Insulation, Types IA, II, III – TIW Type II-HP

Thermal Performance, ASTM C680

	Thickness in. (mm)	Operating Temperature, °F (°C)								
		400 (204)		600 (316)		800 (427)		1,000 (538)		
		HL	ST	HL	ST	HL	ST	HL	ST	
TIW Type I-HP	1	25	109	182	241	275	435	394	699	533
	2	51	61	143	136	201	249	281	409	379
	3	76	43	126	95	171	174	230	287	305
	4	102	32	116	73	153	133	201	221	262
	5	127	27	110	59	141	108	182	179	233
	6	152	22	106	49	133	91	168	151	213
	7	178	19	102	43	126	79	157	130	198
	8	203	17	99	38	121	69	150	114	186
TIW Type II-HP	1	25	81	160	167	225	289	306	453	404
	2	51	45	128	92	167	159	219	251	282
	3	76	31	115	63	145	109	183	173	229
	4	102	23	107	48	131	84	162	132	198
	5	127	19	109	39	123	68	148	106	180
	6	152	16	99	33	117	57	139	89	167

The above table provides approximate heat loss values (HL), Btu/hr•ft², and Surface Temperatures (ST), °F, for flat surfaces. Values are based on horizontal heat flow, vertical flat surface, 80°F ambient temperature, still air, weathered aluminum jacket. To convert heat loss values to W/m², multiply values by 3.15. To convert surface temperatures, use the formula: °C = (°F-32)/1.8.

Thermal Conductivity

	Mean Temp.	k	Mean Temp.	λ
	°F	Btu•in/hr•ft ² •°F	°C	W/m•°C
TIW Type I-HP	75	0.26	25	0.037
	100	0.28	50	0.040
	200	0.38	100	0.055
	300	0.52	150	0.075
	400	0.68	200	0.098
	500	0.86	250	0.124
	600	1.06	300	0.156
TIW Type II-HP	75	0.22	25	0.032
	100	0.23	50	0.033
	200	0.28	100	0.040
	300	0.35	150	0.050
	400	0.43	200	0.062
	500	0.53	250	0.076
	600	0.64	300	0.092

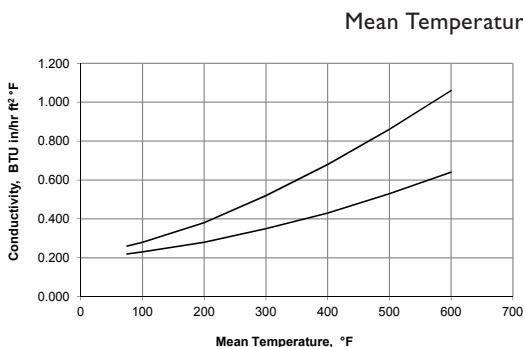

Apparent thermal conductivity curve determined in accordance with ASTM Practice C1045 with data obtained by ASTM Test Method C177. Values are nominal, subject to normal testing and manufacturing tolerances.

Product Data Sheet

PANEL CONSTRUCTION

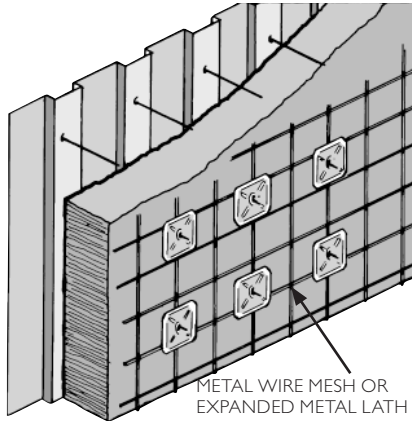

FLUSH APPLICATION – METAL LAGGING

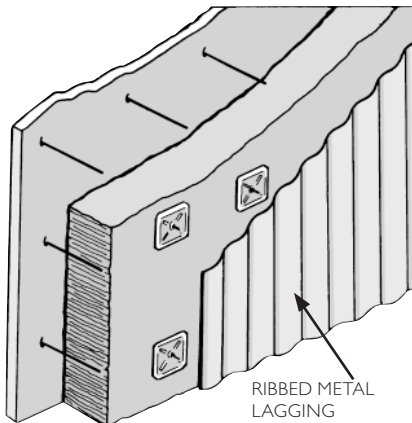

FLUSH APPLICATION – CANVASSED, PAINTED

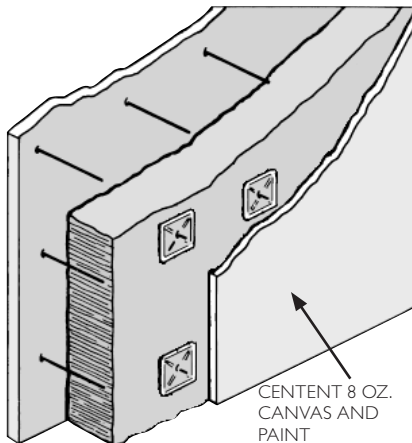

- ASTM C795, Thermal Insulation for Use Over Austenitic Stainless Steel³
- ASTM C1139, Fibrous Glass Thermal Insulation and Sound Absorbing Blanket and Board for Military Applications, Type 1, Grade 2 – TIW Type I-HP; Type 2, Grade 2 – TIW Type II-HP
- Mil. Spec. MIL-I-22023D (Ships), Insulation Felt, Thermal and Sound Absorbing Felt, Fibrous Glass, Flexible, Types 1 & 2, Class 3 – TIW Type I-HP
- Nuclear Regulatory Commission Guide 1.36, Non-Metallic Thermal Insulation³
- U.S. Coast Guard Approval No. 164.109, Noncombustible Materials
- CAN/CGSB-51.11 – Type 1, Class 4 – Fiberglas™ TIW Types I-HP & II-HP Insulation

Environmental and Sustainability

Owens Corning is a worldwide leader in building material systems, insulation and composite solutions, delivering a broad range of high-quality products and services. Owens Corning is committed to driving sustainability by delivering solutions, transforming markets and enhancing lives. More information can be found at www.sustainability.owenscorning.com.

³ Preproduction qualification testing complete and on file. Chemical analysis of each production lot testing required for total conformance.



Fiberglas™ Thermal Insulating Wool (TIW) Types I-HP & II-HP Insulations

Product Data Sheet

Disclaimer of Liability

Technical information contained herein is furnished without charge or obligation and is given and accepted at recipient's sole risk. Because conditions of use may vary and are beyond our control, Owens Corning makes no representation about, and is not responsible or liable for the accuracy or reliability of data associated with particular uses of any product described herein. Nothing contained in this bulletin shall be considered a recommendation.



INNOVATIONS FOR LIVING®

OWENS CORNING INSULATING SYSTEMS, LLC
ONE OWENS CORNING PARKWAY
TOLEDO, OHIO 43659

1-800-GET-PINK®

www.owenscorningcommercial.com

Pub. No. 14729-O. Printed in U.S.A. May 2013. THE PINK PANTHER™ & ©1964-2013 Metro-Goldwyn-Mayer Studios Inc. All Rights Reserved. The color PINK is a registered trademark of Owens Corning. © 2013 Owens Corning. All Rights Reserved.

